

Technical features

- Single-phase power supply: 85-265 Vac 50Hz.
- Fuse: 10AT.
- Stand-by power consumption (loads off): 0.35 W.
- Phase control with triac: speed motor setting and switch with relay.
- Type of motor: single-phase induction.
- Maximum load MOTOR: 4,5A.
- Maximum load LIGHTS: 2A.
- Features for gas solenoid valve: 230 Vac 50Hz MAX. 1A.
- Automatic mode management via NTC temperature probe.
- Digital input, as an alternative to the NTC temperature probe, to control a thermal contact (normally closed) for the protection of the motor windings.
- Digital control settings with 5-key keypad, 1 LED and 1 7-segment LED digit display.
- IP protection: IP56.
- Dimensions: 158x118x77 mm.
- Weight: 0.37 kg.

Technical features

The regulator can be controlled/configured via the 5-key keypad.

Keyboard:

SW1 key: motor starts running, allows the access to the configuration menu and it is used as confirm key when navigating the configuration menu.

SW2 key: torn off the motor, reset the filter usage counter and the filter alarm and it is used as the "Exit" button when navigating the configuration menu.

SW3 key: increases the speed of the motor, allows navigation in the Configuration Menu and allows to enable / disable the Automatic operation.

SW4 key: decreases the motor speed and allows navigation within the Configuration Menu.

SW5 key: turn on/off the light.

8-segments display

It provides indications on the operating status of the regulator and in particular:

- speed implemented by the motor
- any automatic mode active
- any alarms in progress
- Menu level and configuration values in the Configuration Menu.

The display point gives additional indications:

- when it is fixed it indicates that it is inside the Configuration Menu;
- when it is flashing it indicates a phase of transitory operation: acceleration, waiting time to open the gas solenoid valve, waiting time for the motor turning off.

Led

The status of activated Gas Solenoid Valve is indicated by the illuminated LED.

Management of the suction motor, the gas solenoid valve and the lights

The motor can operate in:

- **Manual mode**, 8 preset speeds controlled by Keypad.
- **Automatic mode**, with the supplied NTC temperature probe connected, to automatically adjust the motor speed according to the temperature detected by the probe. Instead of the NTC temperature probe it is possible to manage a digital input for the control of a thermal contact (normally closed) typically destined to the protection of the motor windings: for further information related to the Automatic Mode and to the logic of operation of the aforementioned digital input, refer to the dedicated paragraphs.

In the transition from one speed to the other, as well as at switch-on and switch-off, the motor always follows an appropriate ramp.

Motor start procedure

When the ignition command is given (SW1 key) the motor starts for 3 seconds at the acceleration speed (settable) and then automatically switches to speed 1. Once the set time has elapsed (see the relative configuration mode), the Gas Solenoid valve is activated with the relative lighting of the **DL** LED.

Motor shutdown procedure

At the shutdown command (SW2 key), the gas solenoid valve is immediately deactivated and this event is signaled by the **DL** LED: the motor starts to suck at maximum power (speed 8) for the set time (see relative configuration mode), after which it stops. During the transitory phase that leads to the actual switching off of the engine, the Display Point flashes and the speed can be changed manually.

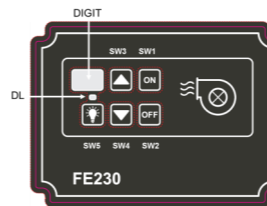

Motor management

With the engine running it is possible to:

- Increase the motor speed in sequence (V1 - V2 - ... - V7 - V8) using the SW3 key on the keyboard;
- Decrease the motor speed in sequence (V8 - V7 - ... - V2 - V1) using the SW4 key on the keyboard.

It is not possible to start the engine with the Speed Increment command and the engine can not be switched off with the Speed Decrease command.

Light Management

At any time and in any operating condition the light can be switched on or off using the SW5 key on the keyboard.

Automatic operation

When an NTC temperature probe is connected to the digital controller, it is possible to enable the Automatic Mode to obtain an automatic and linear adjustment of the motor speed according to the temperature measured by the NTC probe.

The Automatic Mode is activated and deactivated alternately keeping the SW3 key of the keyboard pressed for about 2 seconds when the motor is off and not in the configuration menu. The activation of the Automatic Mode is signaled by the temporary display of the letter "A"; while the deactivation of the Automatic Mode (ie the return to Manual Mode) is signaled by the temporary display of the number "0".

In Automatic Mode, the speed varies between the minimum and the maximum speed set for non-automatic operation: the latter are controlled at settable temperature limits.

The Automatic Mode is active with the motor running, if the regulator is not in the condition of:

- configuration via Menu;
- initial acceleration;
- motor shutdown delay.

The automatism does not control the ON and OFF of the motor-driven fan, but, if activated, regulates its speed.

The automatic operation of the fan is indicated by the letter "A" which alternates with the indication of the non-automatic speed closest to the current one.

To optimize the automatic operation according to the probe position and the size of the extractor hood, it is possible to set from the menu the two temperature limits corresponding to the minimum and maximum engine speeds (see the paragraph dedicated to the Configuration Menu); for intermediate temperatures an intermediate speed is implemented.

Management of a thermal contact for the protection of the motor windings

As an alternative to the NTC temperature probe it is possible to manage a digital input for the control of a thermal contact (normally closed) typically intended for the protection of the motor windings. If this configuration is used, the **Manual Motor Speed Adjustment Mode** must **always** be selected.

As long as the thermal contact is closed, all the functions of the digital controller can be managed:

- turn the engine on/off and increase/decrease the speed by pressing the appropriate keys on the keyboard;
- turn on/off the light;
- access the configuration menu and reset the filter counter.

When the contact opens, any loads that are switched on are switched off and the display shows the indication "c" flashing; if, before the power supply to the regulator is disconnected, the thermal contact closes, the functions that were active before the event of opening the contact are restored (unless the engine shut-off keys have been pressed in the meantime) and/or light).

As long as the thermal contact is open, it is only possible to access the configuration menu and reset the filter counter: any attempts to switch on the engine and / or light have no effect.

Note: with the thermal contact open and in the presence of an eventual filter alarm, the display alternately shows the letter "c" and the letter "F" indicating active filter alarm.

Visualization and management of alarm conditions when the NTC temperature probe is connected to the controller

In critical operating conditions (for example, when the Automatic Mode is active or if the NTC probe wiring may be damaged), the digital controller signals an alarm condition; in particular:

- 1) if the NTC temperature probe is not detected (possible damage to the wiring) or if it returns temperature measurements below the minimum permissible limit, the display will show the letter "c" flashing and possibly alternating with other indications such as specified below;
- 2) if the NTC temperature probe returns temperature measurements above the maximum permissible limit, the display will show the letter "E" flashing and possibly alternating with other indications as specified below.

If the alarm condition occurs with the Automatic Mode activated, the automation remains inhibited until the correct functioning of the probe is restored and:

- if the anomaly occurs with the motor running, then the maximum speed set for the motor is activated and the display shows an alarm code (represented by the letter "c" or the letter "E", as specified above) alternating with the indication of the current speed; in this situation it is always possible, by pressing the appropriate keys on the keypad, to set a different speed of the motor as well as switch off/on the light and the motor;
- when the motor is switched off, a flashing alarm code appears on the display (represented by the letter "c" or the letter "E", as specified above); in this situation it is always possible, by pressing the appropriate keys on the keyboard, to switch on / off the light and the motor and, if necessary, set the desired speed;
- if the anomaly is signaled by the letter "E" you can deselect the Automatic Mode (by pressing for about 2 seconds the SW3 key of the keyboard, as already specified above) in order to use the controller according to the Manual Mode without having any alarm signal to display;
- if the anomaly is signaled by the letter "c" the controller can not be used by deselecting the Automatic Mode: in fact, if in this situation the SW3 key of the keyboard is pressed for about 2 seconds to activate the Manual Mode, the display shows the letter "C" flashing and the light and motor ignition commands are ignored.

FE230/TI - Digital speed regulator for single-phase induction motors with temperature probe



The FE230/TI module is an advanced electronic control system with microprocessor dedicated to the manual or automatic speed regulation of a single phase induction motor (typically intended for applications of air suction), to the management of the lighting system and a solenoid for the gas supply (or other type of load such as, for example, an external solenoid for the chimney's opening). The accuracy and the practicality of use are guaranteed by the use of a last generation microprocessor and by digital commands from the front panel. This model can work both in manual or automatic mode. The instructions below explain its functioning.

WARNINGS:

- Before installing and plugging the device into the mains, check the integrity of the appliance, check that the specifications indicated on the data plate and the technical characteristics explained on this manual correspond to those of the electrical mains system, of motor, of lighting system and of eventual gas solenoid valve.
- Always use high quality and suitable section electric cables wire to connect the regulator to the mains and to loads.
- During the installation of the appliance, pay particular attention not to damage the sheath of the power cable.
- If the power cable (not supplied) is damaged, it must be replaced by authorized personnel, using an equal or better quality cable.
- We recommend that you keep within the device the lengths cable short to avoid their contact with particular components that could reach high temperatures.
- It is advised to use cable glands (at least IP55 or IP68) or suitable fittings that have enough space for the cables to exit but avoid seepage of moisture and condensation.
- Install the regulator in ventilated places and away from sources of heat, especially if the current load absorption are close to the maximum declared.
- Be sure to connect the ground wire of the motors (or the chassis of the motors) to the main board and the latter one to the grounding system of the network.
- To avoid danger of fire, electric shock or malfunctions, do not expose the device to rain, humidity, favouring the installation in a dry place. It is recommended to not install the regulator in areas with moisture, fumes or gas, avoid direct sunlight or heat sources that could damage the device dissipation capacity.
- The regulator must be installed and used only in compliance with the instructions provided: the manufacturer won't be responsible for the improper use of the device (if it is used for applications different than those for which it was designed) or for failure to comply with these warnings.
- The appliance can be used by children under 8 years of age and by people with reduced physical, sensory or mental abilities, or without experience or necessary knowledge, provided that they are under surveillance or after they have received instructions relating to the safe use of the appliance and an understanding of the dangers inherent in it. Children must not play with the appliance. Cleaning and maintenance intended to be carried out by the user must not be carried out by children without supervision.
- Before carrying out any maintenance or cleaning operation, make sure that you have disconnected the appliance from the power supply.
- In case of failure or malfunction, turn off the appliance, disconnect the power supply and call the manufacturer.

- The manufacturer declares that this product is free from manufacturing defects.
- The guarantee lasts 12 months if the product is correctly used.
- The manufacturer reserves the right to make changes, also without notice, on the device or on the documentation in order to improve its performances.

Regulator installation

After removing the cover, make the necessary holes on the box for the passage of the cables, the cable glands and of the temperature probe. Then set the box to the desired support and connect to the terminal block on the board respecting the connection scheme. (Note: If the motor used in the installation has a metallic chassis, it is recommended to connect this to the one of the two terminal blocks on the board. The second terminal then will be connected to the earth by the electricity grid). Connect the temperature probe to CN1 connector on the board.

After making the connections, provide supply to the regulator. This will remain in low power mode (standby) until will be activated outputs or will enter to the Configuration menu.

Check the outputs correct operation using the special keys on the front panel.

Then close the cover using the screws: the device is ready for use.

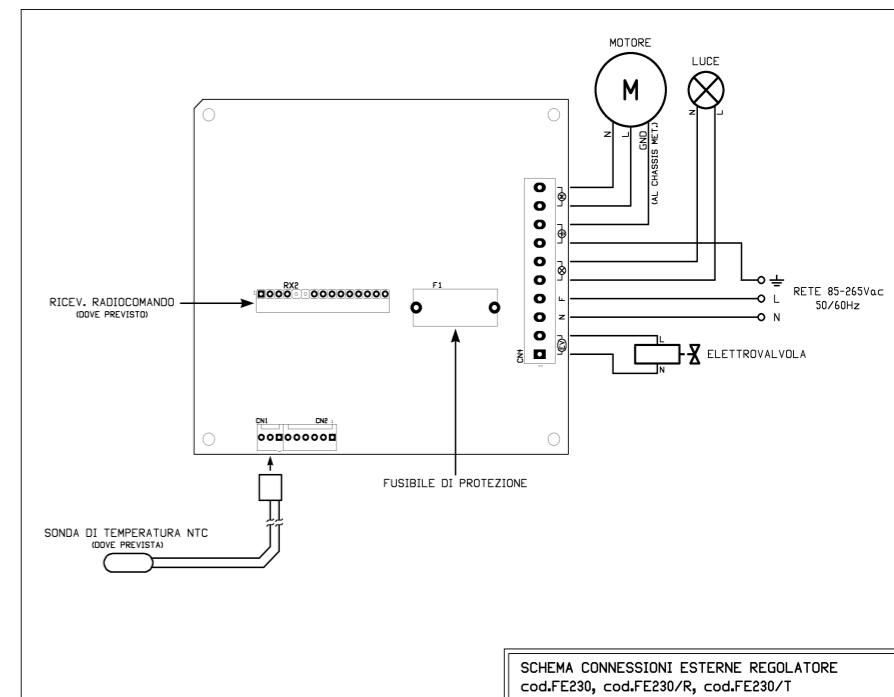

If the alarm condition occurs when the Automatic mode is deactivated, only the anomaly related to point 1 (NTC probe not detected or temperature measurement below the minimum permissible limit) is signaled and managed, and in particular:

- if the anomaly occurs with the motor running, then the motor and the light are switched off and the display shows the alarm code represented by the letter "c" flashing;
- after the motor and light have been switched off, any light and motor ignition commands are ignored and the display continues to show the letter "c" flashing ;
- if the alarm condition ends before the power supply to the controller is removed, the active functions are restored before the alarm occurs (unless these functions have been disabled from the keypad or remote control after the alarm event occurs same); with the alarm returned, the display no longer shows the letter "c" flashing;
- if with active alarm the Automatic Mode is selected (by pressing the SW3 key of the keyboard for about 2 seconds, as already specified above) the automatism will be inhibited, but it will be possible to use the controller to switch the light on / off, switch on / off the motor and change its speed using the appropriate keyboard commands; in this case the display shows the letter "c" alternating with the indication of the current speed.

Note: with NTC probe alarm in progress and in the presence of a possible filter alarm, the display alternately shows the alarm code (represented by the letter "c" or by the letter "E", as specified above) and the letter "F" for signaling active filter alarm.

Reset filter alarm

When the motor is switched off and the configuration menu is not active, pressing the SW2 key on the keyboard for about three seconds resets the filter usage hours counter and any filter alarm.

Regulator configuration

Configuration menu

With motor off, access the Configuration Menu by keeping the "SW1" key pressed for at least 3 seconds. The keys of the keyboard allow navigation in the Configuration Menu as follows:

- **SW1** key ("**ENTER**") : Confirm value set or Input in submenu.
- **SW2** key ("**ESC**") : Output without saving the set value or ascent in the submenu tree.
- **SW3** key ("**UP**") : Value increase during setting or scrolling of the active submenu items.
- **SW4** key ("**DOWN**") : Value decrease during setting or scrolling of the active submenu items.

"P" menu: the "P" menu is the entry point in the Configuration Menu and allows setting the starting, minimum and maximum speed; use the **UP** button to switch to the "T" menu. With the **ESC** key, you exit the Configuration Menu.

Use the **ENTER** key to enter the submenu to set the starting speed "b" (boost). The motor moves to the minimum speed that can be associated with this parameter (it should be noted that this speed, depending on the type of load applied, may not be sufficient to start the engine, in which case press the **UP** key to increase it when the engine starts). The speed can be changed to the desired point with the **UP** and **DOWN** keys.

With the **ENTER** key, the current speed is acquired as the starting speed and the minimum "L" speed setting submenu is entered (Low); with the **UP** and **DOWN** keys the motor speed can be brought to the desired minimum level; it is not possible to select a speed greater than that chosen for the starting speed.

With the **ENTER** key, the current speed is acquired as minimum speed (1) and the submenu for setting the maximum speed "H" (High) is entered; the motor goes to the maximum speed (8) that can be changed to the desired point with the **UP** and **DOWN** keys.

With the **ENTER** key, the current speed is acquired as the maximum speed (8); the intermediate speeds are automatically calculated; the 8 speeds plus the inrushing speed are memorized and you return to the "P" menu.

Pressing the **ESC** key in the submenus "b", "L", and "H" returns to the "P" menu without saving any speed settings.

Menu "t" : the "t" menu allows to set the delay for the actual switching off of the motor upon receiving the switch-off command (see engine shutdown procedure); use the **UP** key to go to the "F" menu while using the **DOWN** key to switch to the "P" menu. With the **ESC** key, you exit the Configuration Menu. Press **ENTER** to enter the submenu for setting the switch-off delay; with the **UP** and **DOWN** keys you can choose between 10 possibilities (from 0 to 9) to which the times correspond as follows:

0: 0 sec. 1: 20 sec. (default) 2: 40sec. 3: 60 sec. 4:80 sec.
5:100sec.
6: 120 sec. 7: 140 sec. 8: 160 sec. 9: 180 sec.

With the **ENTER** key, the selected delay is acquired and memorized, and you return to the "t" menu.

Pressing the **ESC** key returns to the "t" menu without saving the current setting.

Menu "F": the "F" menu allows to set the engine operating hours before generating, for their saturation, a Filter Alarm; press the **UP** button to go to the "E" menu, while the **DOWN** button will go to the "t" menu. With the **ESC** key, you exit the Configuration Menu.

Use the **ENTER** key to enter the submenu for setting the saturation hours; with the **UP** and **DOWN** keys you can choose between 10 possibilities (from 0 to 9) to which the times correspond as follows:

0:0 hours (Default – alarm OFF) 1: 10 hours 2: 20 hours 3: 30 hours 4:40 hours
5: 50 hours 6: 60 hours 7: 70 hours 8: 80 hours 9: 90 hours

With the **ENTER** key, the filter duration hours are acquired and stored and you return to the "F" menu.

Pressing the **ESC** key returns to the "F" menu without saving the current setting.

"E" menu: the "E" menu allows to set the activation delay of the Gas Solenoid valve when the motor is switched on (see Motor starting procedure); use the **UP** key to go to the "A" menu, while using the **DOWN** key to go to the "F" menu. With the **ESC** key, you exit the Configuration Menu.

With the **ENTER** key you enter the submenu for setting the activation delay of the Gas solenoid valve; with the **UP** and **DOWN** keys you can choose between 10 possibilities (from 0 to 9) to which the times in the following table correspond:

0: 1 sec. 1: 10 sec. 2: 20 sec. (default) 3: 30 sec. 4: 40 sec.
5: 50 sec. 6: 60 sec. 7: 70 sec. 8: 80 sec. 9: 90 sec.

With the **ENTER** key, the selected delay is acquired and stored and you return to the "E" menu.

Pressing the **ESC** key returns to the "E" menu without saving the current setting.

"A" menu: the "A" menu allows setting the temperature limits to which minimum and maximum speed correspond in automatic mode; press the **UP** button to go to the "I" menu while using the **DOWN** button to go to the "E" menu. With the **ESC** key, you exit the Configuration Menu.

Press **ENTER** to enter the submenu for selecting the temperature limit to be set; with the **UP** and **DOWN** keys it is possible to select the lower temperature limit indicated by the letter "L" (Low) or the upper temperature limit indicated by the letter "H" (High); press **ENTER** to enter the relative temperature selection submenu, and return to menu "A" with the **ESC** key.

Submenu "L": with the **UP** and **DOWN** keys you can choose between 4 possibilities (from 1 to 4) to which the temperatures correspond as follows:

1: 25°C 2: 30°C (default) 3: 35°C 4: 40°C

Press **ENTER** to acquire and store the selected temperature level and return to the "L" menu.

Press the **ESC** key to return to the "A" menu without saving.

Sub-menu "H": with the **UP** and **DOWN** keys you can choose between 6 possibilities (from 1 to 6) to which the temperatures correspond as follows:

1: 45°C 2: 50°C (default) 3: 55°C 4: 60°C 5: 65°C 6: 70°C

With the **ENTER** key, the selected temperature level is acquired and stored and you return to the "H" menu.

Press the **ESC** key to return to the "A" menu without saving.

Restore default settings

To restore the default configuration of the controller, enter the Configuration Menu (first menu level) and keep the SW3 and SW4 keys pressed simultaneously for at least 3 seconds; the exit from the Configuration Menu with simultaneous temporary display of the letter "d" indicates the successful restoration.

This operation involves restoring the default conditions for:

- the 8 speeds of non-automatic operation
- the starting speed
- the activation delay of the gas valve when the fan is switched on
- the delay in switching off the motor
- the hours of filter saturation (Alarm disabled)
- Automatism (disabled).